

CAD FILE:

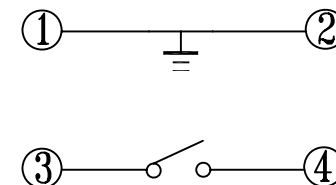

SCHEMATIC

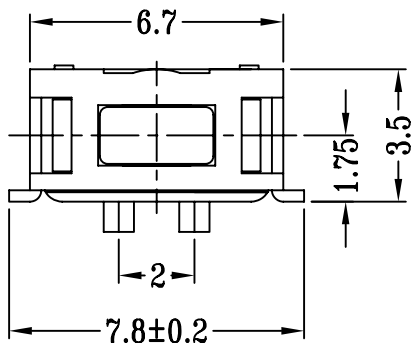
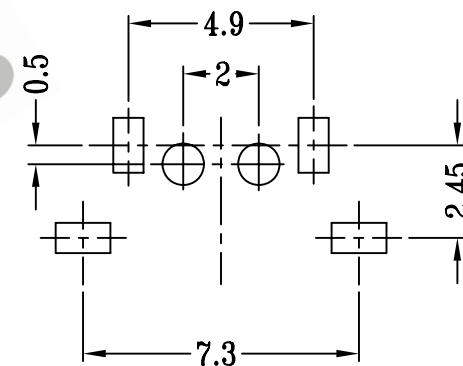
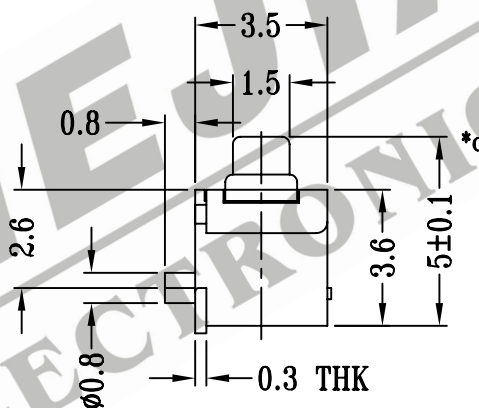
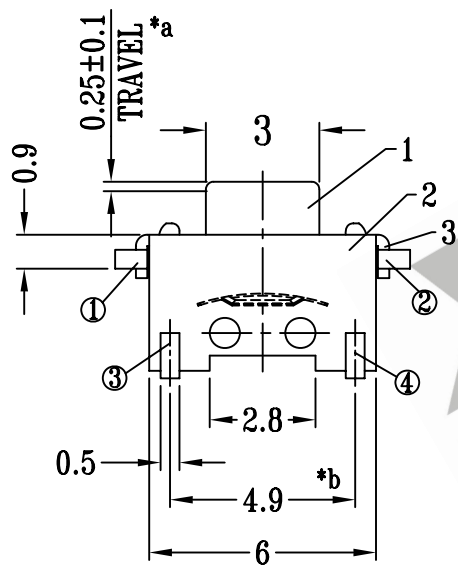

P.C.B LAYOUT

注：“*”表示关键尺寸（3个）

8					TOLERANCE	SHENZHEN XIEJIA ELECTRONICS CO.,LTD.					
7					UNLESS SPECIFIED						
6					WITHIN: 1.5±0.1mm						
5					OVER: 1.5±0.2mm	ISSUE	DATE	DESCRIPTIONS OF REVISION	APPD.		
4	CONTACT	SUS	1	Ag CLAD	TITLE : TACT SWITCH			UNIT : mm	DRWG NO.: XJ-DR-TD30EA-00		
3	COVER	STEEL STRIP	1	Ag PLATED OVER Ni PLATED	MODEL: TD-30EA			SCALE: 5:1	DWN.	ZHOUYU	2003-6-8
2	CASE	NYLON+F.G/0.3mm BRASS STRIP	1	BLACK/Ag PLATED OVER Ni PLATED	ALL MATERIALS MUST BE COMPLIANT TO ROHS				CHK'D	FANGYING	2003-6-8
1	KNOB	NYLON	1	IVORY					APPD.	KANGXINAN	2003-6-8
NO.	PARTS	MATERIALS	Q'TY	FINISH							